X-BAG

Aperto Torantriebe GmbH

X-Bag

Table of Contents

Product description

Dimensioned drawing

Parts list

Charging procedure

Additional technical information during the charging procedure

Additional technical information during activation of the gate operator

Additional technical information on exhaustive discharge warning

View of electronic battery charging module

Inside view of X-Bag

X-Bag spare parts list

Car Charger

Wall mounting fixture

Dimensioned drawing of wall mounting fixture

X-Bag

Product description

The X-Bag is a mobile, solar-operated power supply unit for operating sectional doors, tip-up doors, up-and-over doors, ceiling track doors, side-opening doors and side sectional doors for charging at a mains connection. With the Aperto Car Charger, it is optionally possible to charge the X-Bag via the cigarette lighter in the car or by means of an Aperto solar module.



All the components and additional devices described in these instructions are designed to be operated and connected only in accordance with the X-Bag operating instructions. Any other use is expressly prohibited and will render the warranty null and void. In addition, use of the X-Bag for other than its intended purpose may pose unforeseen risks and hazards.

Dimensioned drawing of X-Bag



Weight: 12.7 kg

Dimensioned drawing of X-Bag

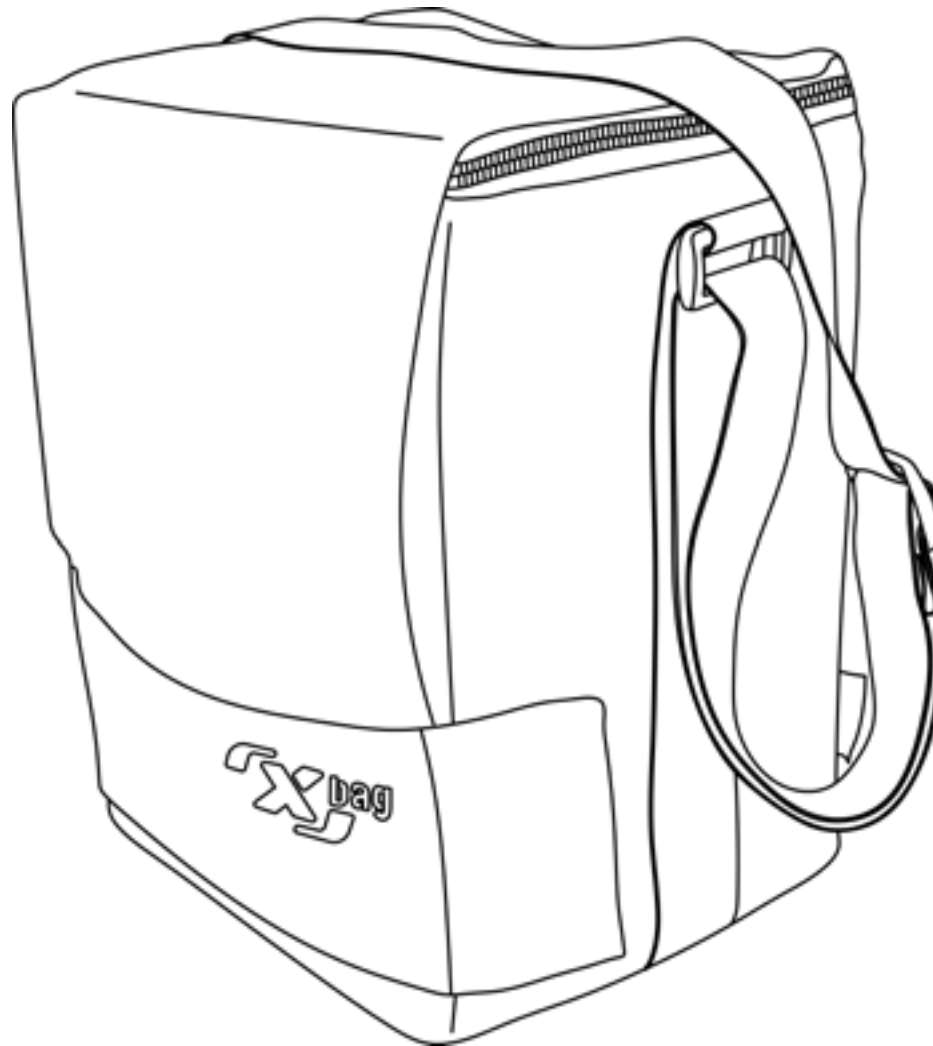

Dimensioned drawing of X-Bag

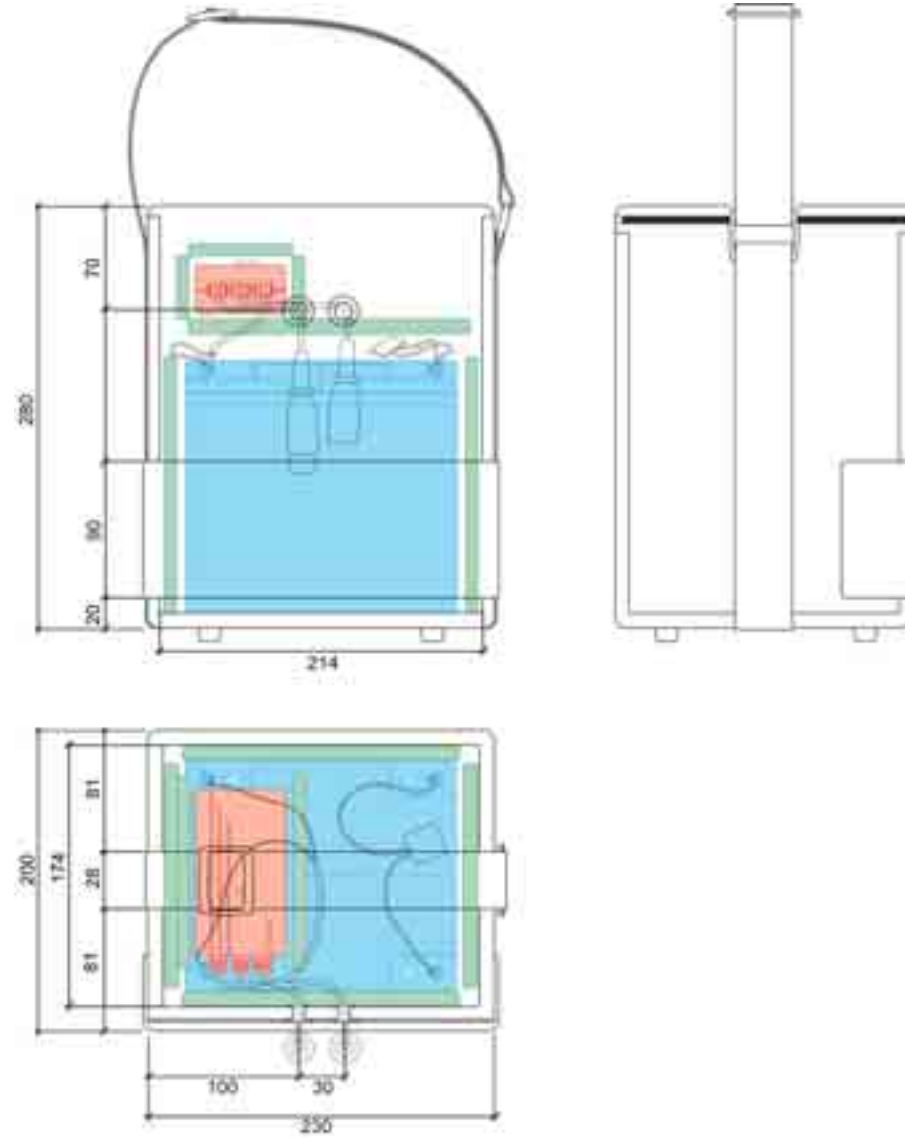

X-Bag parts list

- Central PCB
- 2 Battery units each 18 AH/12 V
- Adapter charging cable from XLR coupling to mains charger connector
- Mains charger
- Car Charger (optional)

X-Bag charging procedure

Connect the charging cable (X-Charger) to the supplied adapter and plug into the X-Bag coupling (socket on right). The gate operator is connected to the socket on the left.



Red LED on X-Charger is constantly lit:

Charging now begins.

Charging takes between approx. 20 - 30 hours.

The yellow intervals of the LED become longer while the red intervals become shorter.

Additional technical information **during the charging procedure**

The procedure described in the following is not essential. It merely serves the purpose of providing an additional check when charging the batteries:

Open the zip fastener on the X-Bag. The bag contains an X-Charger (charging cable) and an adapter.

Remove these components. A padded protective cover that is secured by means of a strap can now be seen.

Unfasten the strap and carefully remove the protective cover. This cover also contains the electronic charging module for the batteries. Carefully remove the electronic charging module from the padded soft case. There is a red LED indicator lamp (see additional technical information during activation of the gate operator) and a green LED indicator lamp on the housing .

When the green LED flashes, the battery is being charged.

When the green LED is lit, the charging operation is almost finished, however, a low current is still being fed to the batteries. The X-Bag cannot be overcharged!



Additional technical information
during activation of the gate
operator

The procedure described in the following is not essential. It merely serves the purpose of providing an additional check when activating the gate operator:

Open the zip fastener on the X-Bag. The bag contains an X-Charger (charging cable) and an adapter.

Remove these components. A padded protective cover that is secured by means of a strap can now be seen.

Unfasten the strap and carefully remove the protective cover. This cover contains the electronic charging module for the batteries. Carefully remove the electronic charging module from the padded soft case. There is a red and a green LED indicator lamp on the housing (see additional technical information during the charging procedure).

When the red LED is lit, the gate operator is currently active.

When the red LED flashes, there is a fault.



Additional technical information on exhaustive discharge warning

The procedure described in the following is not essential. It merely serves the purpose of providing an additional check:

Open the zip fastener on the X-Bag. The bag contains an X-Charger (charging cable) and an adapter.

Remove these components. A padded protective cover that is secured by means of a strap can now be seen.

Unfasten the strap and carefully remove the protective cover. This cover contains the electronic charging module for the batteries. Carefully remove the electronic charging module from the padded soft case. There is a red LED indicator lamp (see additional technical information during activation of the gate operator) and a green LED indicator lamp (see additional technical information during the charging procedure) on the housing.

The exhaustive discharge warning may trip if the X-Bag is used for a longer period of time without recharging (also if not used for a period of several months). The red and green LEDs flash together at the same rate. A loud audible signal also sounds. The X-Bag now needs to be recharged immediately. If the X-Bag is not recharged despite these warnings, the electronic module will switch off the gate operator after a certain period of time. Automatic gate operation is then no longer possible. This is indicated by the rapid flashing of the red LED. The X-Bag must now be recharged otherwise the batteries will be irreparably damaged.



**View of electronic charging module
and batteries**



Inside view of X-Bag
- Protective padding -



Inside view of X-Bag
- Electronic charging
module/batteries -



X-Bag spare parts list

- Battery unit in the bag
- Adapter charging cable
- Car Charger (optional), Item No.: AZ11736

Car Charger (optionally available)

The Car Charger (optionally available) is a charger used to recharge the X-Bag from the vehicle socket (cigarette lighter). Make sure that the vehicle socket is not switched off when the ignition key is removed. The vehicle battery must also be in very good condition.

The battery unit should be charged only while driving. Make sure that the battery unit is recharged while in an upright position with the handle facing upwards.

Dimensions of Car Charger

Length x width x height in cm:

11 x 6 x 3.5

Item No.: AZ11736

Material:

Non-flammable ABS



Car Charger (optionally available)

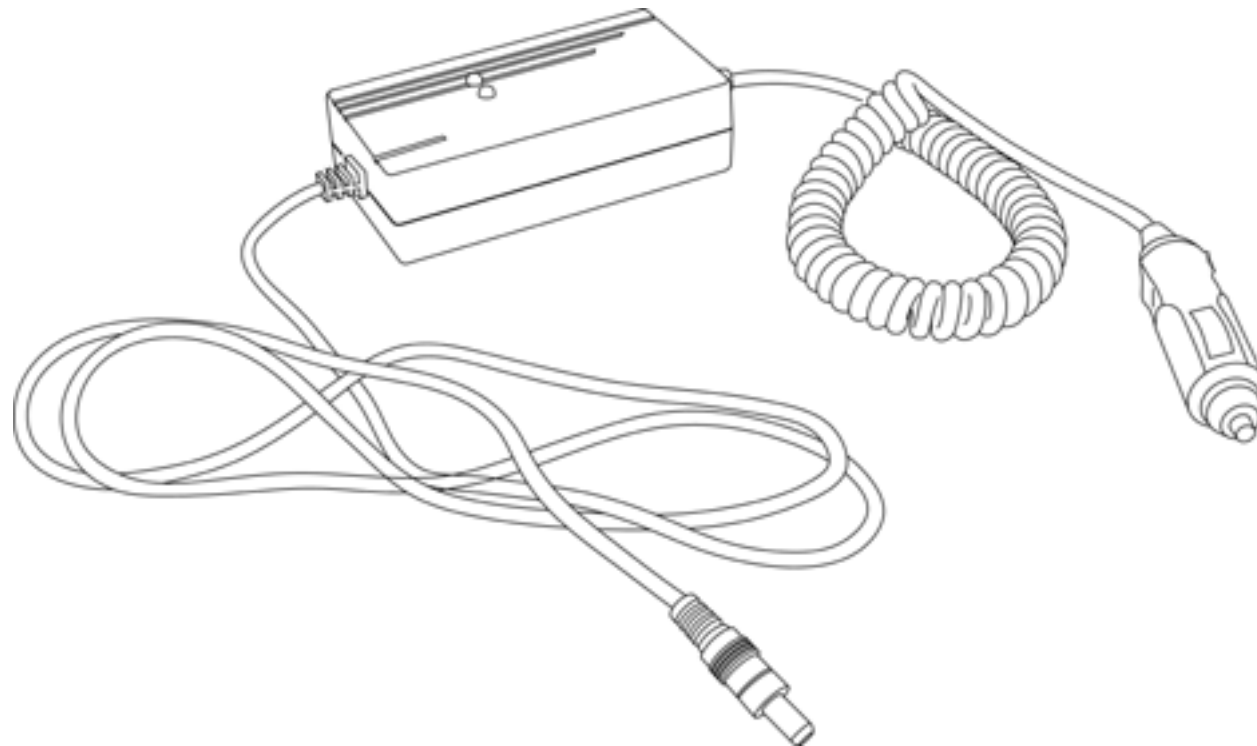

Perspective of Car Charger

Car Charger (optionally available)

Dimensioned drawing of Car Charger
- including glass tube fuse -

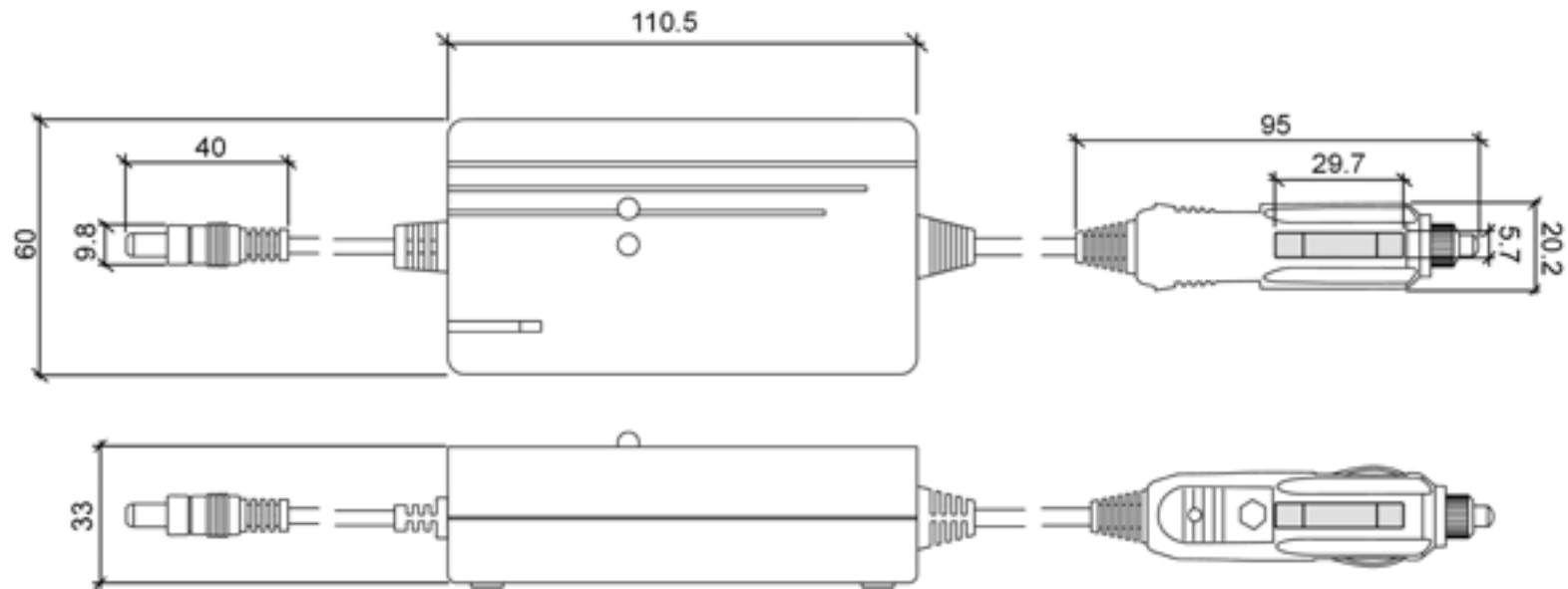

Top view and side view

Wall mounting fixture of X-Bag

The wall mounting fixture is made of 1.5 mm thick powder-coated sheet steel.

The following mounting material is supplied:

4 DIN screws, galvanised including
DIN dowels, galvanised.

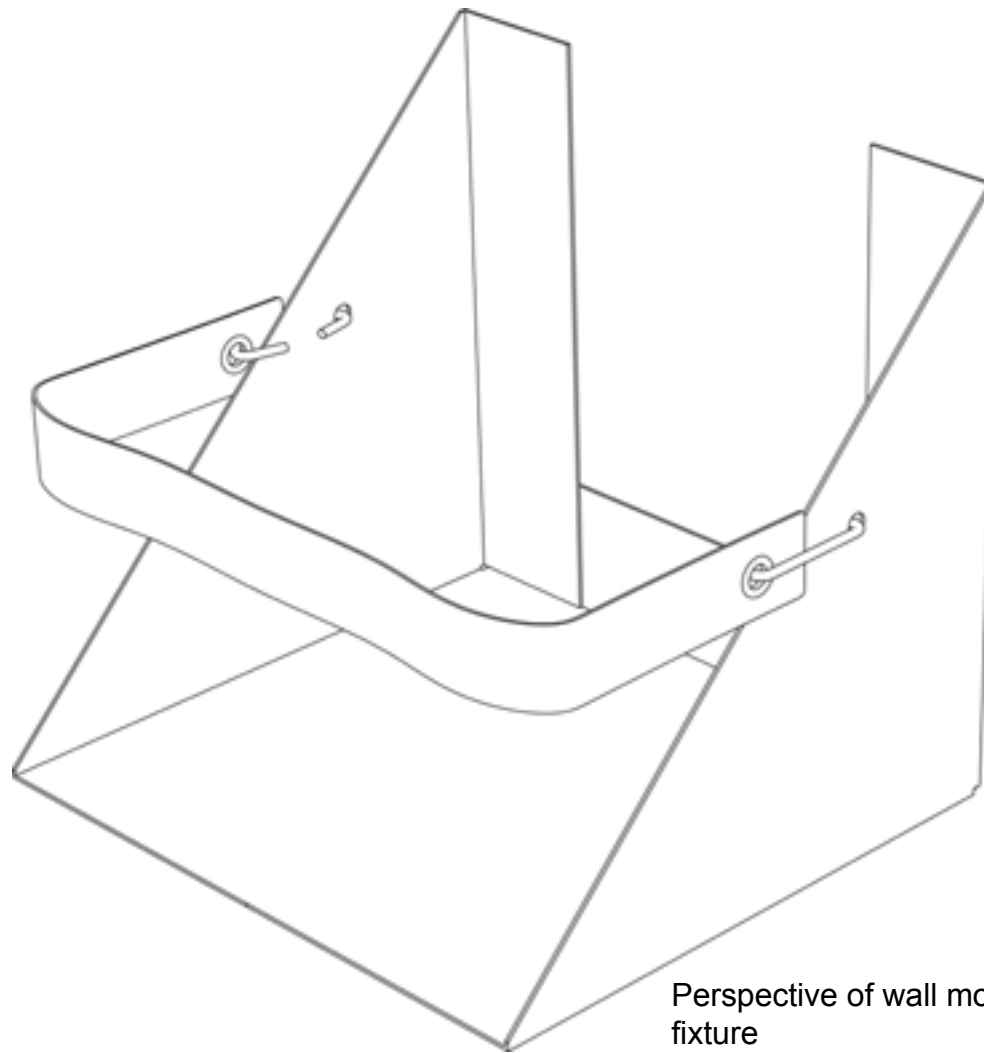

Perspective of wall mounting
fixture

Dimensioned drawing of X-Bag wall mounting fixture

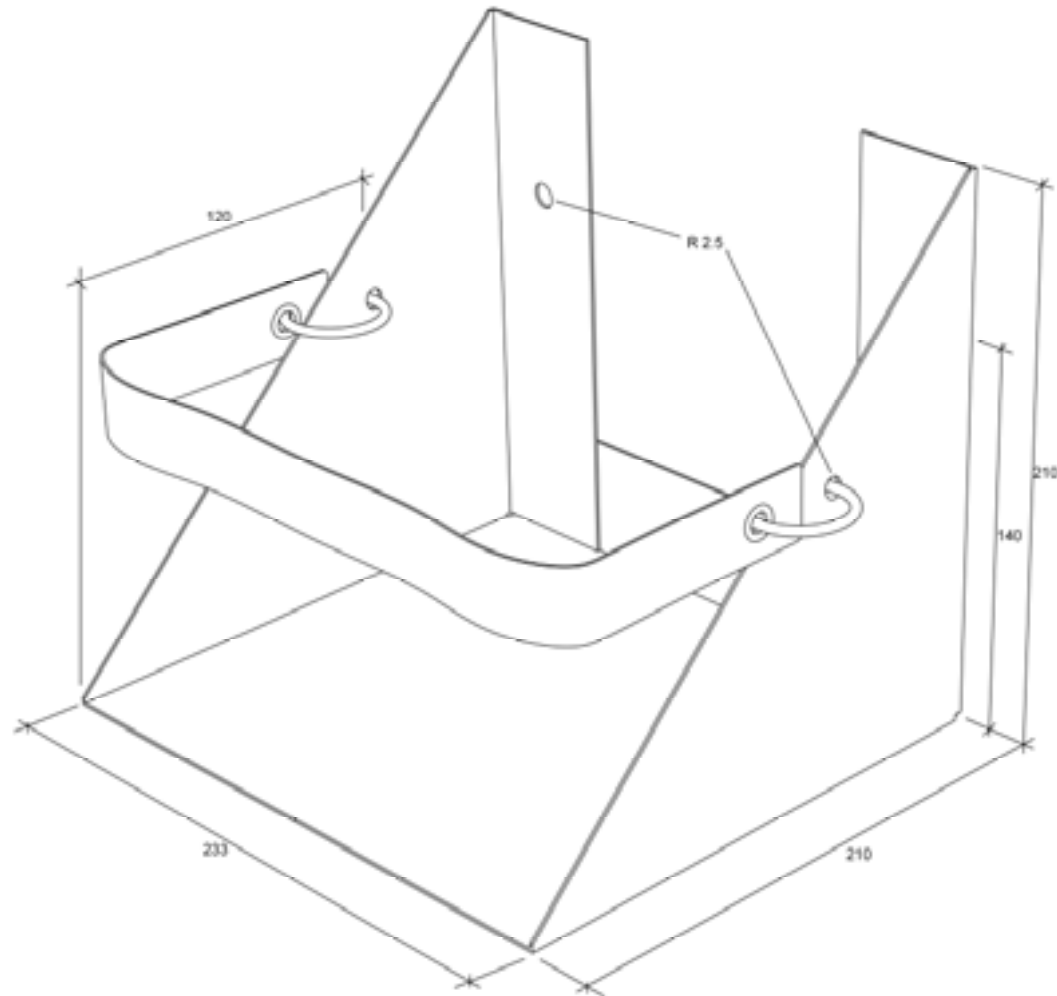

**Dimensioned drawing of X-Bag wall
mounting fixture**

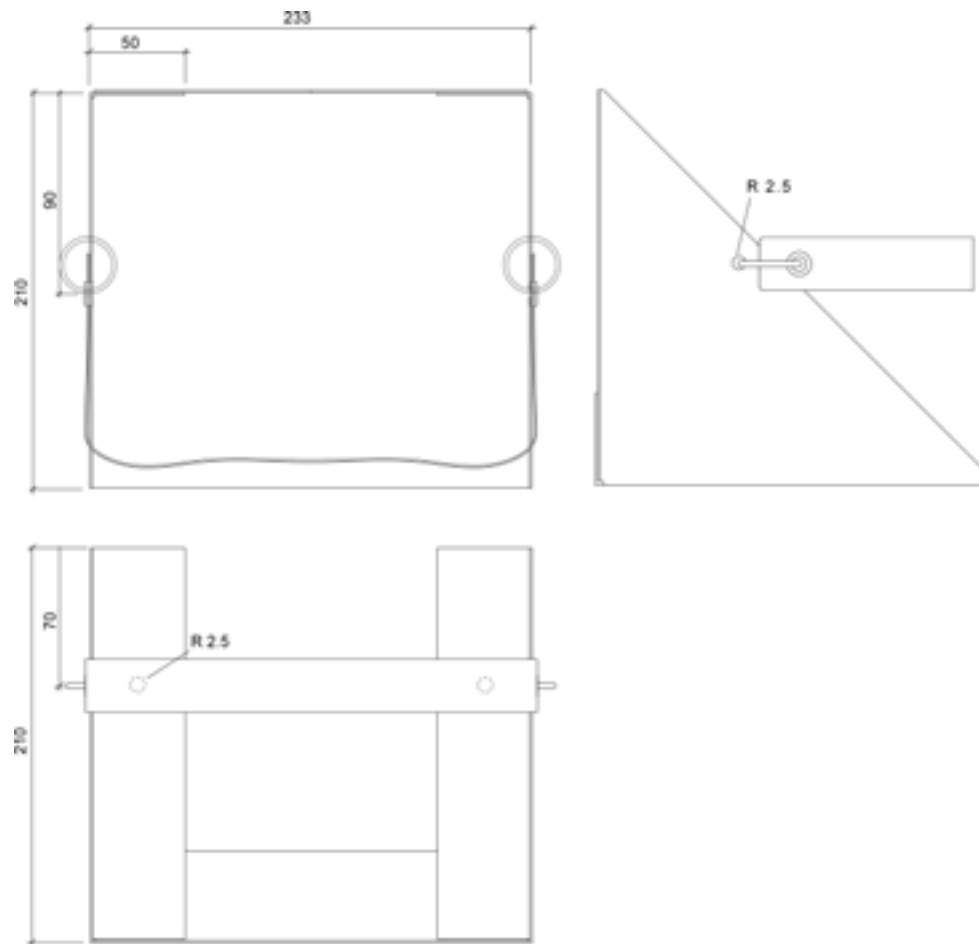

Top view and side view